

Tianyu Product Book 2023



Professional Manufacture of Metallurgical Cooling Equipment



Ironmaking Division

Cast Iron Stave Cooler

Chequer Support Set Cast Iron

Tuyere Cooler

Slag Runner for Blast Furnace

Steelmaking Division

BOF lip ring casting

Cast Iron Water Jacket



Catalog



General Castings Division

OEM castings multiple size and material

Ironmaking products

Cast Iron Stave Cooler

Cast iron stave coolers are applied to blast furnace shell, which can cooling down the furnace shell in order to effectively extending the BF working life.



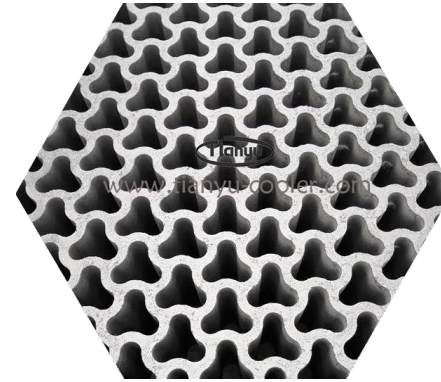

Chequer Support Set

Chequer support set is combined by Columns, Grids and Girders. Detailed engineering will be according to different designs.

A Pre-assembling before shipment at workshop will be performed to as part of acceptance inspection.

Cast Iron Tuyere Cooler

Large Tuyere Cooler is water cooling cast iron part which is normally connect with Medium and Small copper tuyeres as a set of tuyeres using to transfer hot wind into BF.



Slag Runner for Blast Furnace

Using to transport slags out of BF.

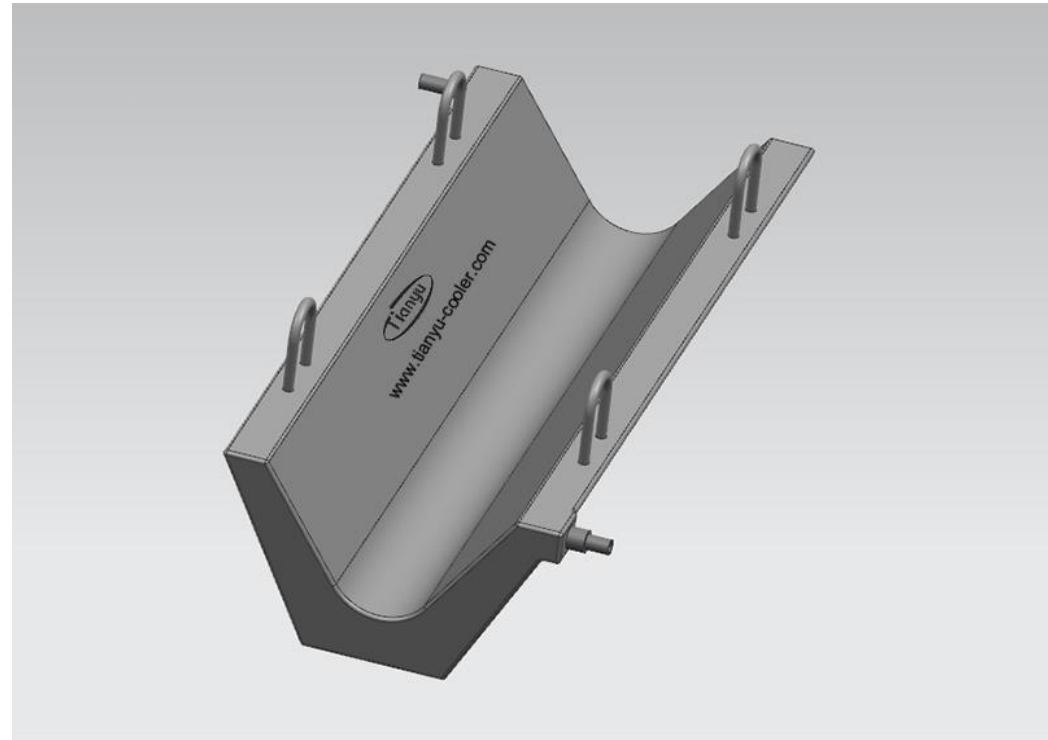

Steelmaking products

Water-Cooling Converter Mouth

According to different BOF designs, the lip ring casting basically has 2 different types:

- Water cooling lip ring castings;
- Solid casting iron lip ring casting(without cooling pipe).



Cast Iron Water Jacket

The water jacket is the feeding part of the steelmaking converter or the mixed iron furnace.



General Castings Division

With 3 casting work shops, Tianyu can produce OEM cast iron parts according to customer designs.

Size: from 10kg to 10 tons.

Material: according to technical requirement.

Casting method:

- coated sand casting
- resin sand casting
- Lost Foam Casting

Innovation design:

Tianyu is an openminded company who is interested to be part of the innovation work. If you have new castings no matter how is the volume we would like to do test casting with you to achieve your new design.



E-mail: cathyli@tianyu-cooler.com

Mobile phone: +86 177 6717 3240



Contact Us